

- NEW EASEMENTS SUMMARY**
- EMT C in Lot 4478 is for Energex (PMT Clearance)
  - EMT I in Lot 4511 is for Energex (PMT Clearance)
  - EMT U in Lot 9003 for Logan City Council (Sewer & Water)
  - EMT Z in Lot 9003 for Logan City Council (Sewer)

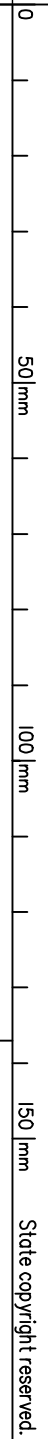
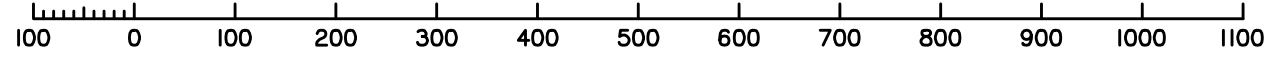
**Area of New Road**  
1.148 ha

**9003 (Pt)**  
1.137 ha  
SEE DIAGRAM H  
(Sheet 10)

**9003 (Pt)**  
99.04 ha  
(103.4428 ha) Total

**PRELIMINARY**

Scale 1:7500 - Lengths are in metres.



Preliminary Issues			
No.	Drawn	Checked	Date
A	MD	MK	09/10/24
			Issue for Disclosure Plan

**Plan of Lots 4478-4480, 4502-4525, 4527-4565 & 9003, Emt C in Lot 4478, Emt I in Lot 4511 and Emts U & Z in Lot 9003**

Canelling Lot 9003 on SP348245

LOCAL GOVERNMENT: LOGAN CITY

LOCALITY: GREENBANK

Meridian: MGA (Zone 56) wide PSMS

Scale: 1:7500  
State copyright reserved.

Format: STANDARD

**PRELIMINARY**

SP348261

P8.1

(Dealing No.)

4. Lodged by

(Include address, phone number, email, reference, and Lodger Code)

I. Existing		Created		
Title Reference	Description	New Lots	Road	Secondary Interests
	Lot 9003 on SP348245	4478-4480, 4502-4525, 4527-4565 & 9003	New Rd	Emts C, I, U & Z

**ENCUMBRANCE EASEMENT ALLOCATIONS**

Easement	Lots to be Encumbered
601266225 (Emt A on RP214312)	9003
601266225 (Emt B on RP214312)	9003
712220840 (Emt X on SP207516)	9003
712329523 (Emt Y on SP207517)	9003
720314657 (Emts G & H on SP312154)	9003
721023221 (Emts J & K on SP327528)	9003
721476938 (Emt D on SP331504)	9003
721476939 (Emt AA on SP331504)	9003
721476940 (Emt BB on SP331504)	9003
722337718 (Emt Y on SP338104)	9003
722621066 (Emt H on SP334725)	9003
722721358 (Emt AC on SP334746)	9003
(Emt L on SP344892)	9003
(Emt M on SP344892)	9003
(Emt Q on SP344914)	9003
(Emt S on SP344914)	9003
(Emt T on SP344914)	9003
(Emt V on SP344914)	9003
(Emt N on SP348245)	9003
(Emt O on SP348245)	9003
(Emt P on SP348245)	9003
(Emt W on SP348245)	9003

**BENEFIT EASEMENT ALLOCATIONS**

Easement	Lots Fully Benefited	Lots Partially Benefited
719454124 (Emt E on SP307780)		9003

**EXISTING ADMINISTRATIVE ADVICE ALLOCATIONS**

Administrative Advice	Lots to be Encumbered
719945618 (Veg Notice)	4478-4480, 4502-4525, 4527-4565 & 9003

(Emt R on SP344914) is absorbed by new road.

(Emt S on SP344914) is partially absorbed by new road.

**PRELIMINARY**

**6. Building Format Plans only.**

I certify that :  
 \* As far as it is practical to determine, no part of the building shown on this plan encroaches onto adjoining lots or road;  
 \* Part of the building shown on this plan encroaches onto adjoining \* lots and road

.....  
 Cadastral Surveyor/Director\* Date  
 \*delete words not required

**7. Lodgement Fees :**

Survey Deposit	\$ .....
Lodgement	\$ .....
.....New Titles	\$ .....
Photocopy	\$ .....
Postage	\$ .....
TOTAL	\$ .....

8. Insert Plan Number **SP348261**

9003	Pors 434 & 436
4478-4480, 4502-4525, 4527-4565 & 9003	Por 434

Lots	Orig
------	------

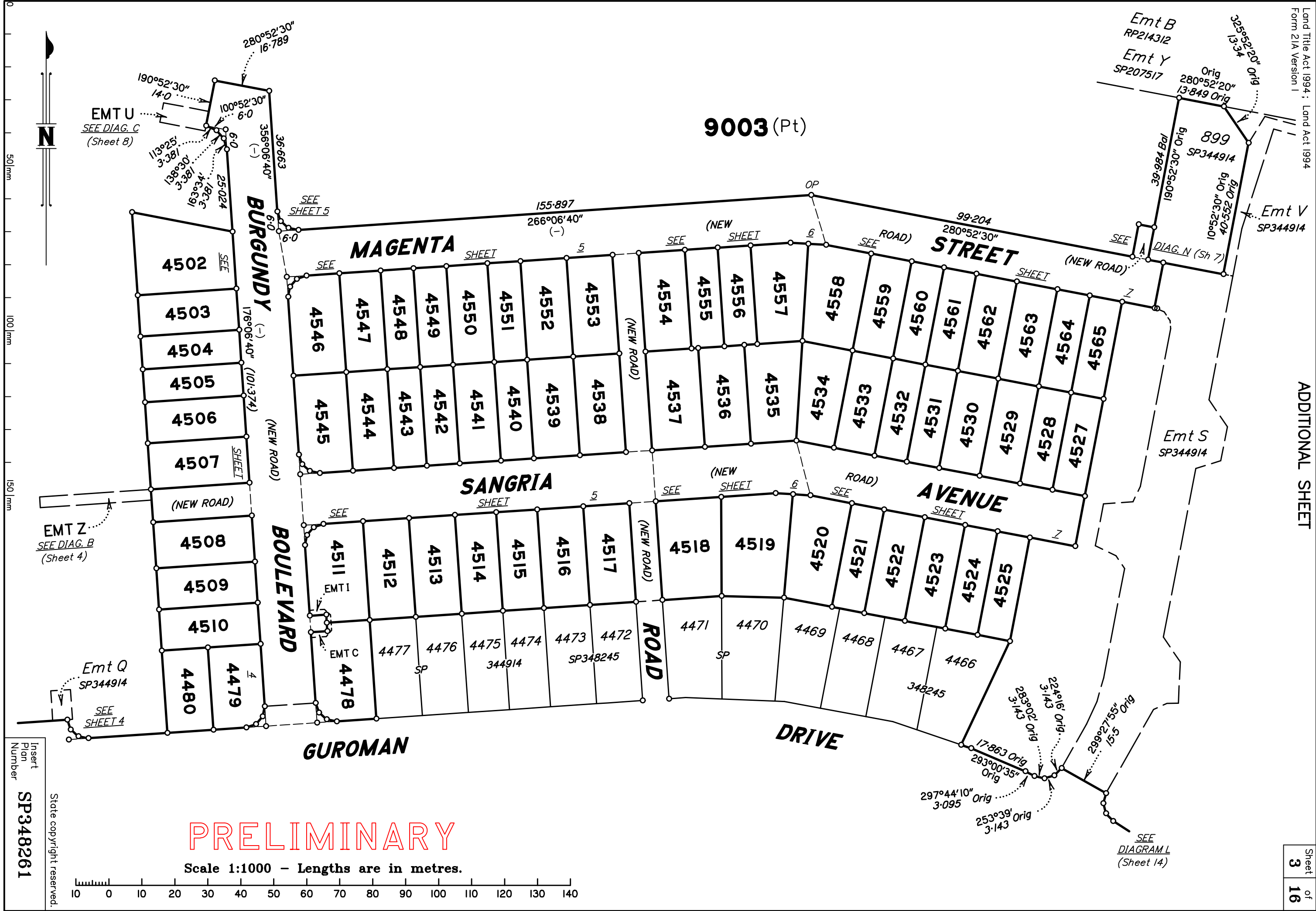
2. Orig Grant Allocation :

3. References :  
 Dept File :  
 Local Govt :  
 Surveyor : **7598-P8.1** Survey Advice: 2018-0912

5. Passed & Endorsed :

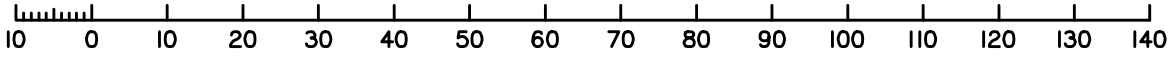
By: **SAUNDERS HAVILL GROUP PTY LTD**  
 Date :  
 Signed :  
 Designation : **Endorsing Officer**

9003 (Pt)



PRELIMINARY

Scale 1:1000 - Lengths are in metres.



Insert  
Plan  
Number  
SP348261

State copyright reserved.

50mm  
100mm  
150mm

EMT U  
SEE DIAG. C  
(Sheet 8)

EMT Z  
SEE DIAG. B  
(Sheet 4)

Emt Q  
SP344914  
SEE SHEET 4

SEE SHEET 5

SEE SHEET 5

SEE SHEET 6

SEE SHEET 6

SEE DIAG. N (Sh 7)

SEE DIAGRAM L  
(Sheet 14)

EMT U  
SEE DIAG. C  
(Sheet 8)

EMT Z  
SEE DIAG. B  
(Sheet 4)

Emt Q  
SP344914  
SEE SHEET 4

SEE SHEET 5

SEE SHEET 5

SEE SHEET 6

SEE SHEET 6

SEE DIAG. N (Sh 7)

SEE DIAGRAM L  
(Sheet 14)

ADDITIONAL SHEET

DIAGRAM A

1:100

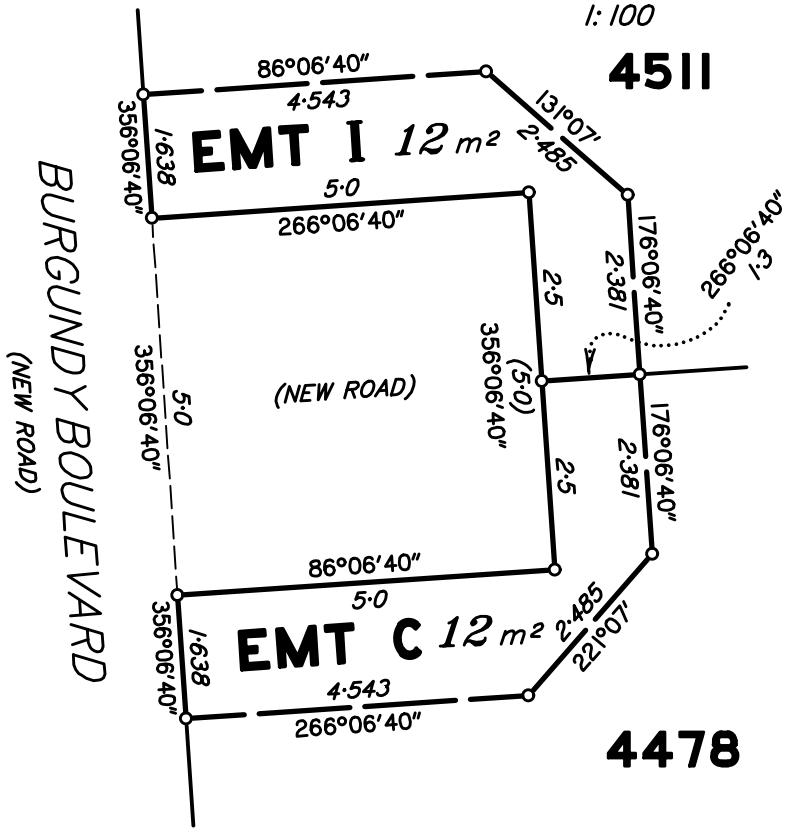
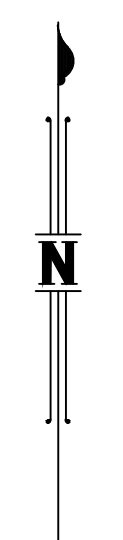
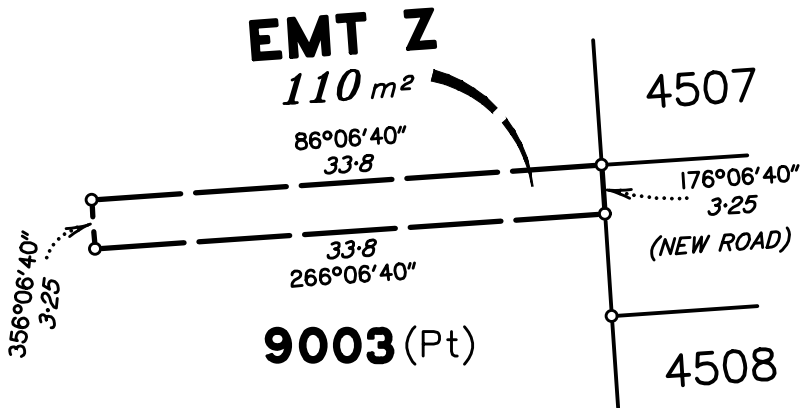
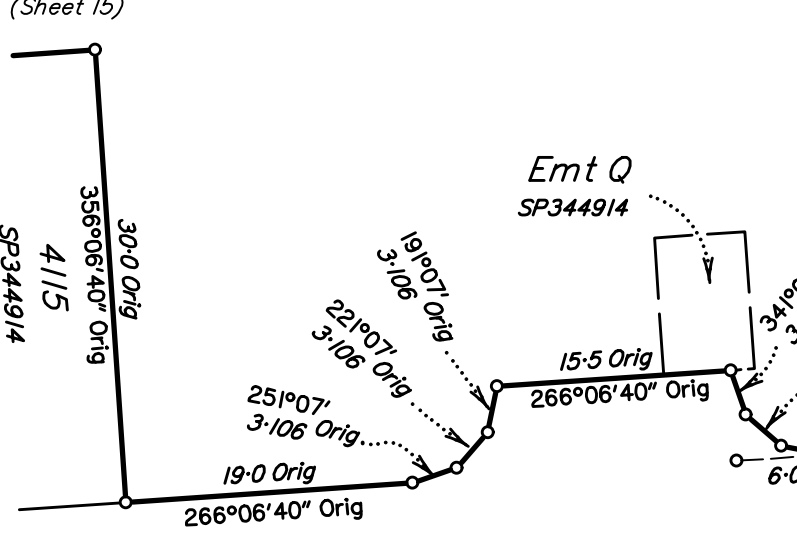


DIAGRAM B

1:500

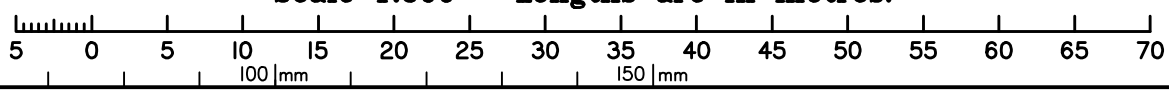


SEE DIAGRAM M (Sheet 15)



GUROMAN

Scale 1:500 - Lengths are in metres.



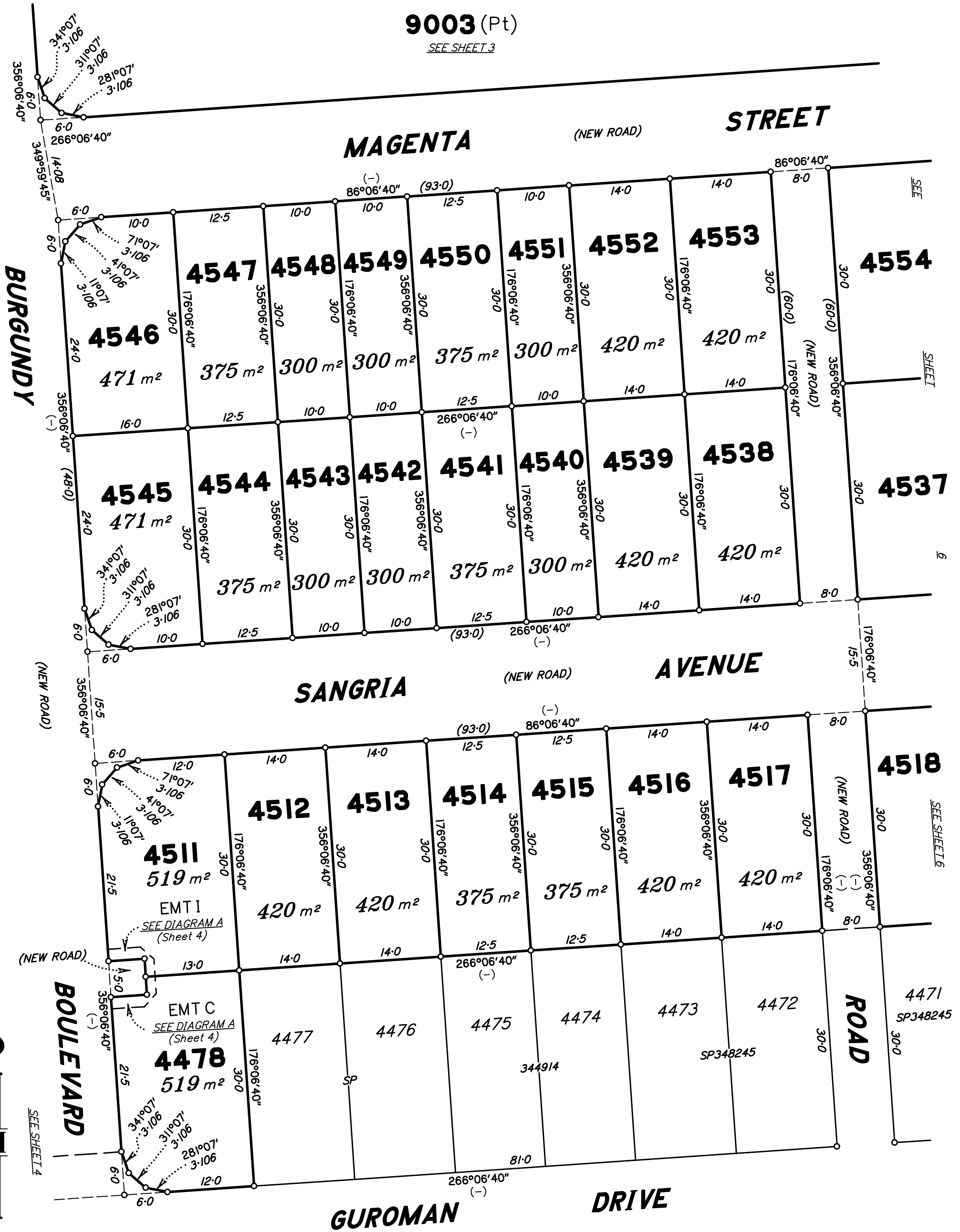
State copyright reserved.

Insert Plan Number SP348261

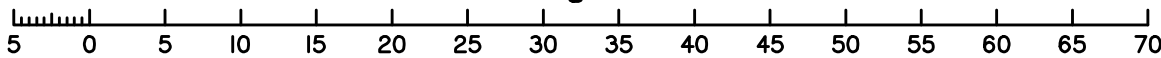
PRELIMINARY

9003 (Pt)

SEE SHEET 3



Scale 1:500 - Lengths are in metres.



State copyright reserved.

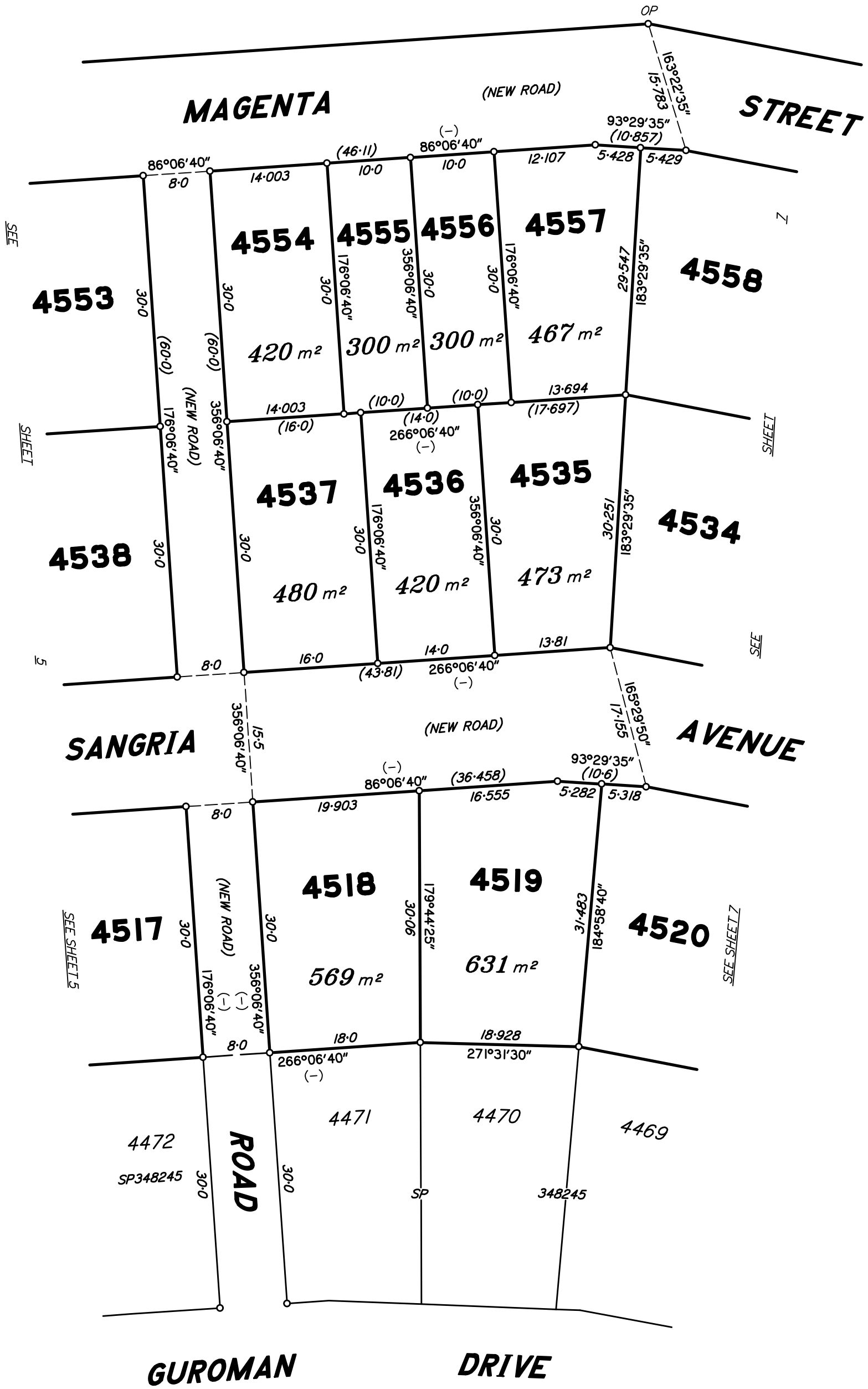
Insert Plan Number **SP348261**

50|mm 100|mm 150|mm

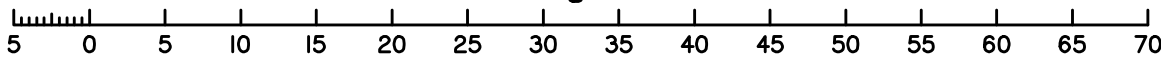
PRELIMINARY

9003 (Pt)

SEE SHEET 3



Scale 1:500 - Lengths are in metres.



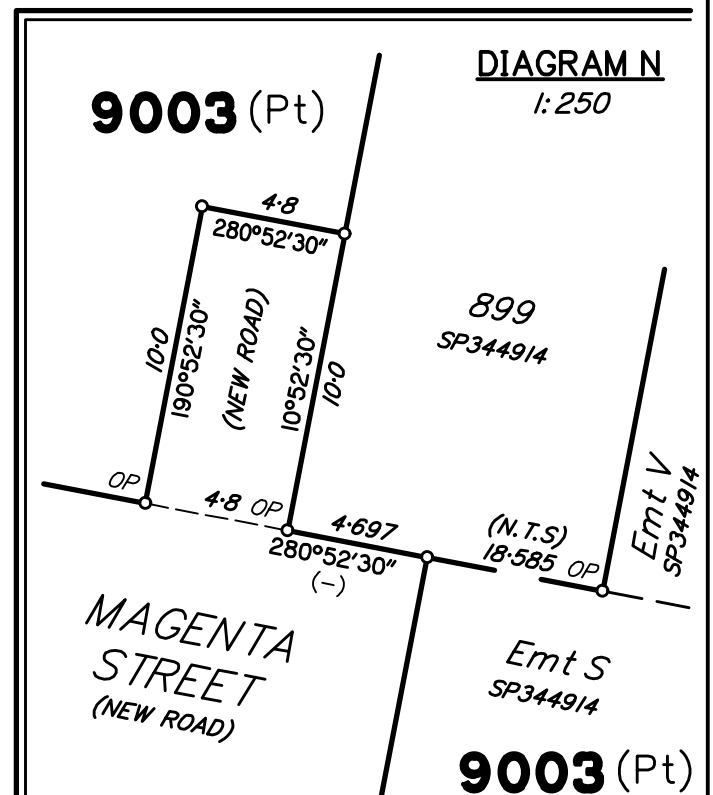
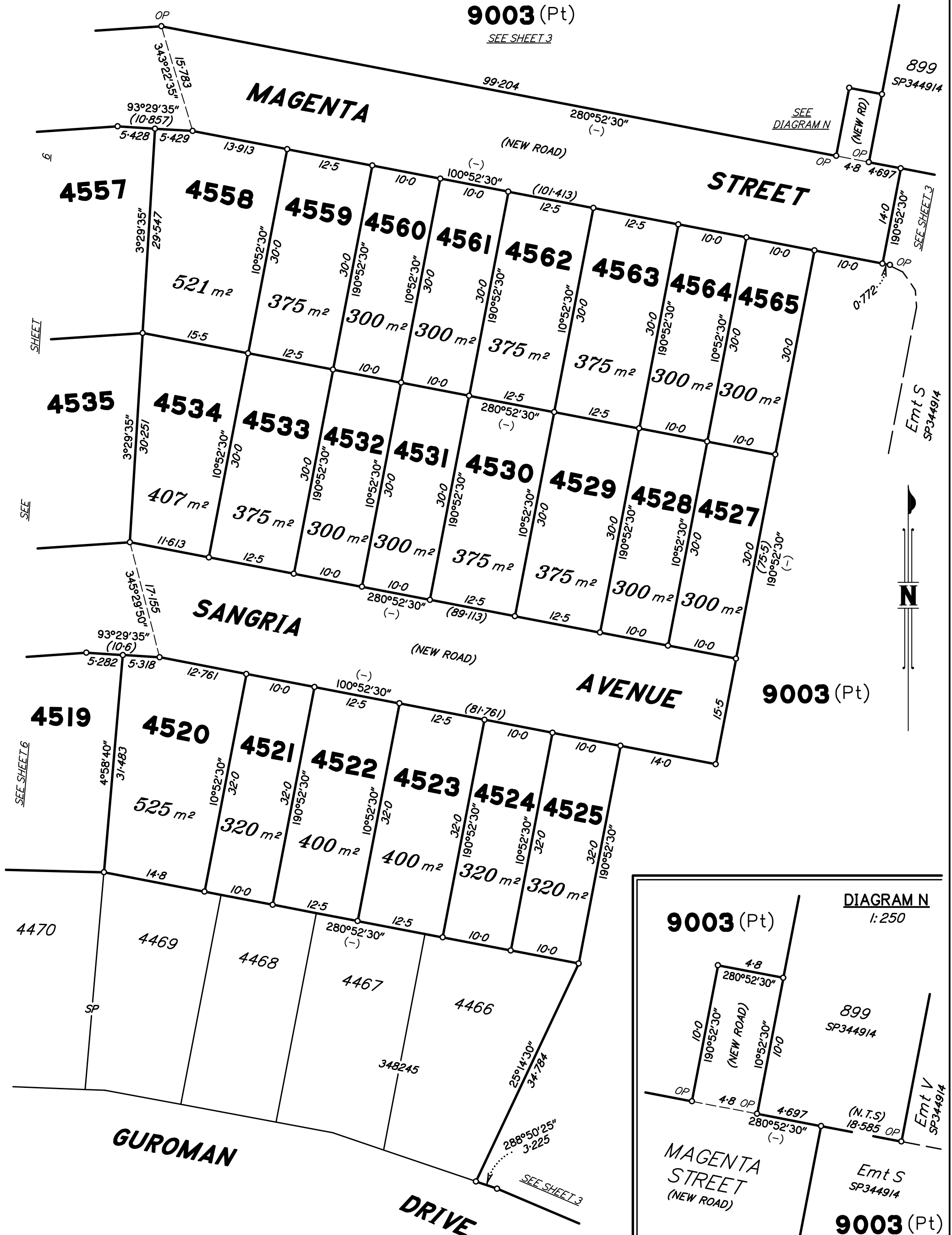
State copyright reserved.

Insert Plan Number **SP348261**

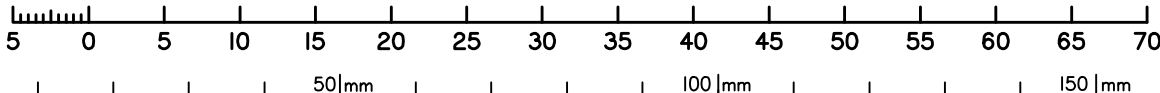
# PRELIMINARY

## 9003 (Pt)

SEE SHEET 3



Scale 1:500 - Lengths are in metres.



Insert Plan Number

SP348261

State copyright reserved.

PRELIMINARY

ADDITIONAL SHEET

DIAGRAM D  
1:2000

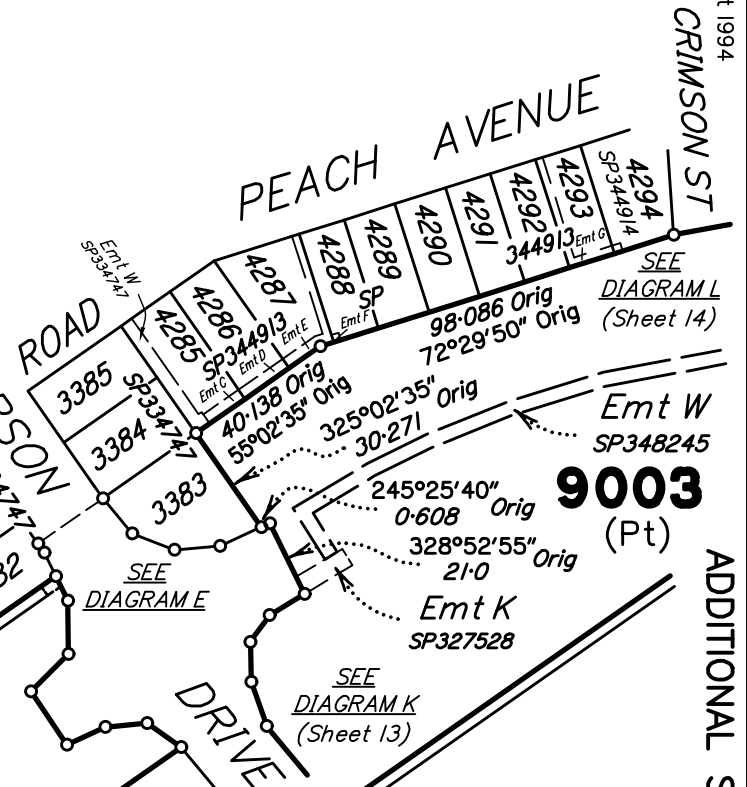


DIAGRAM C  
1:300

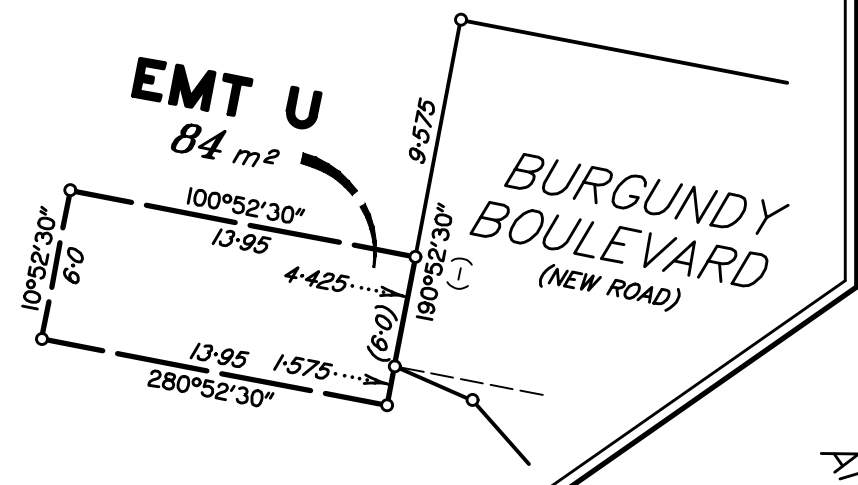


DIAGRAM E  
1:500

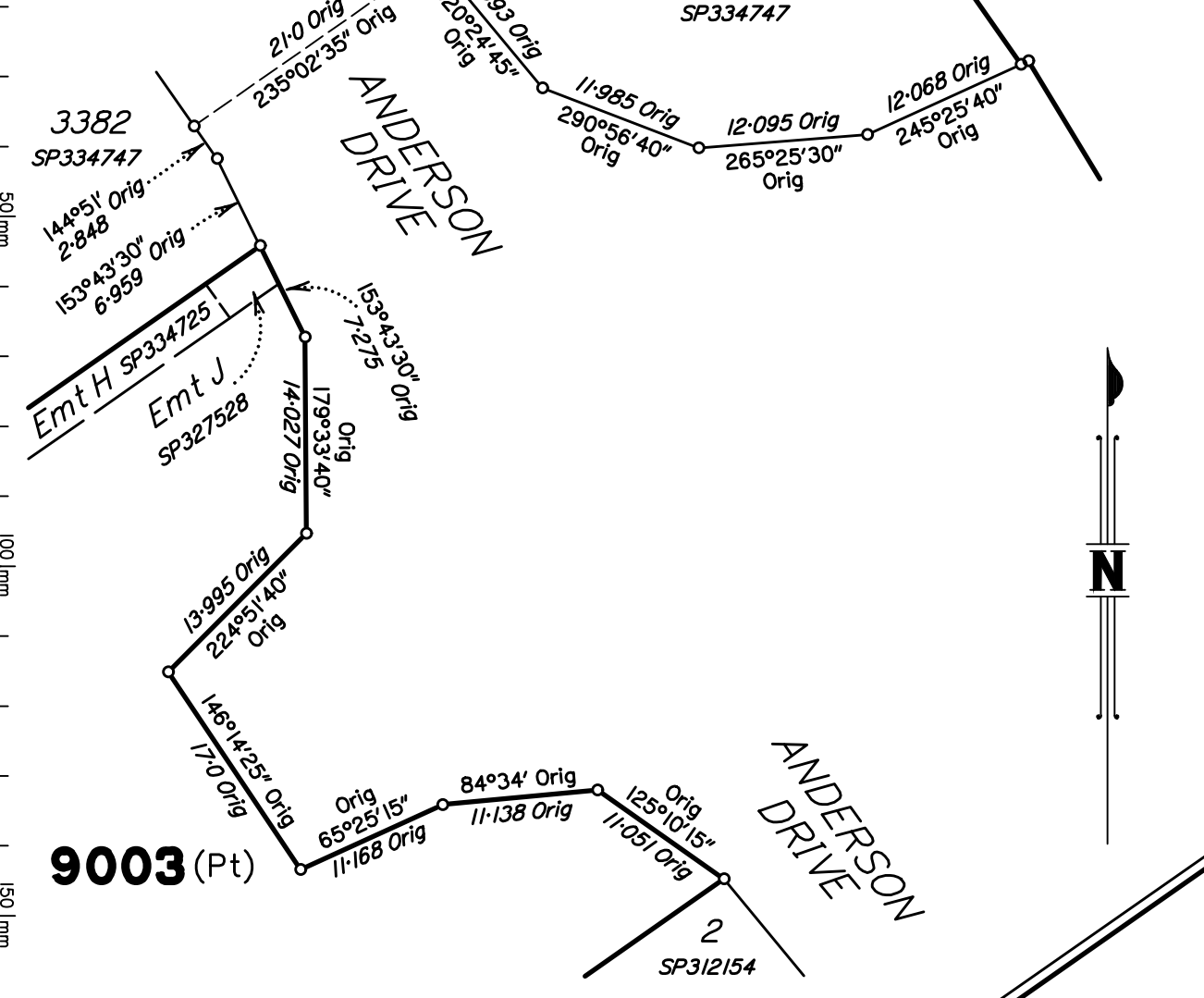
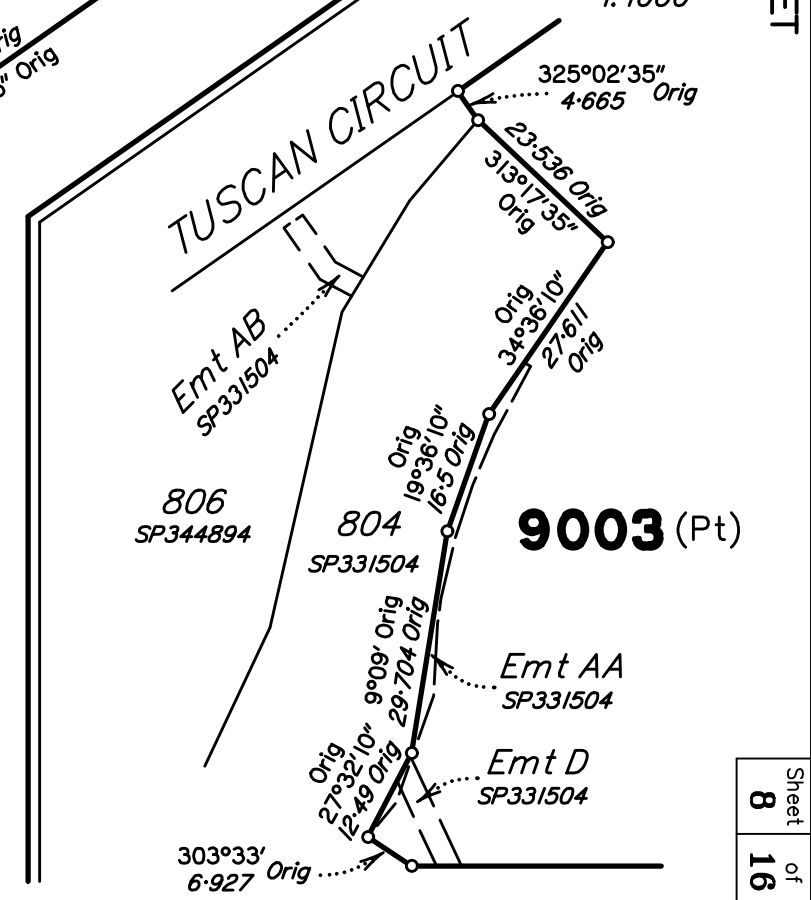
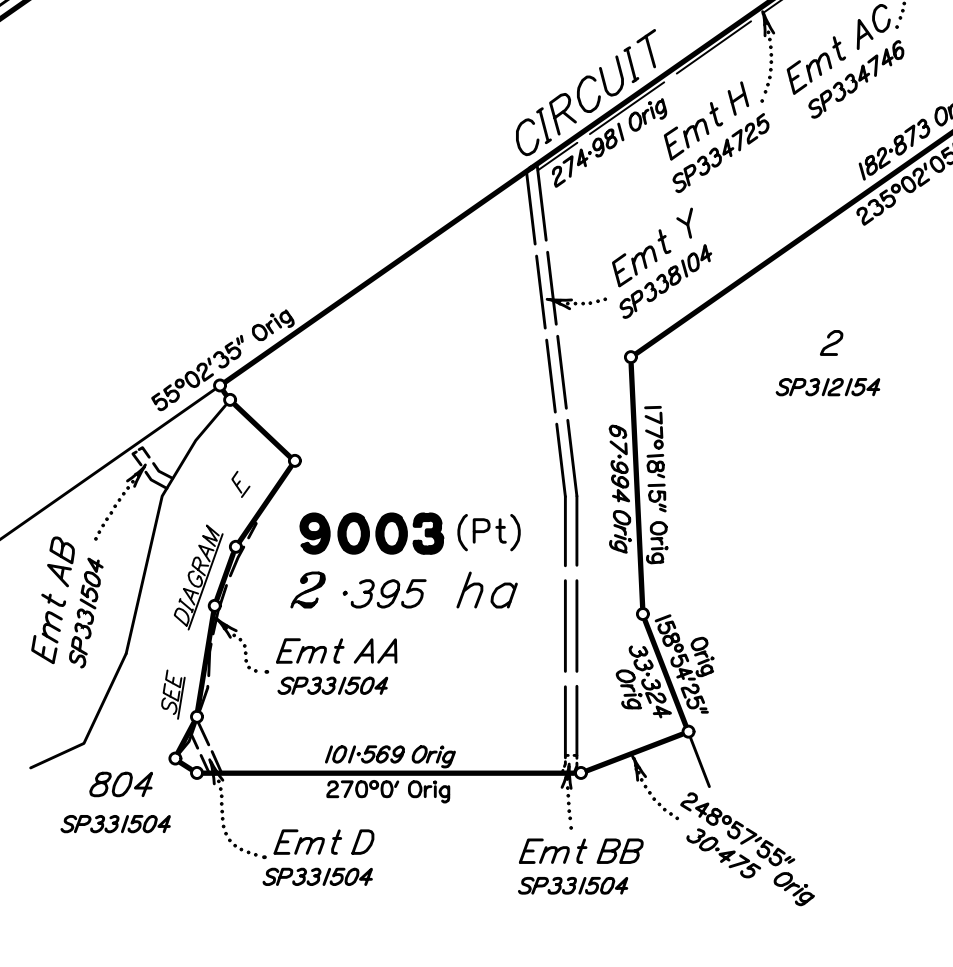


DIAGRAM F  
1:1000



CIRCUIT

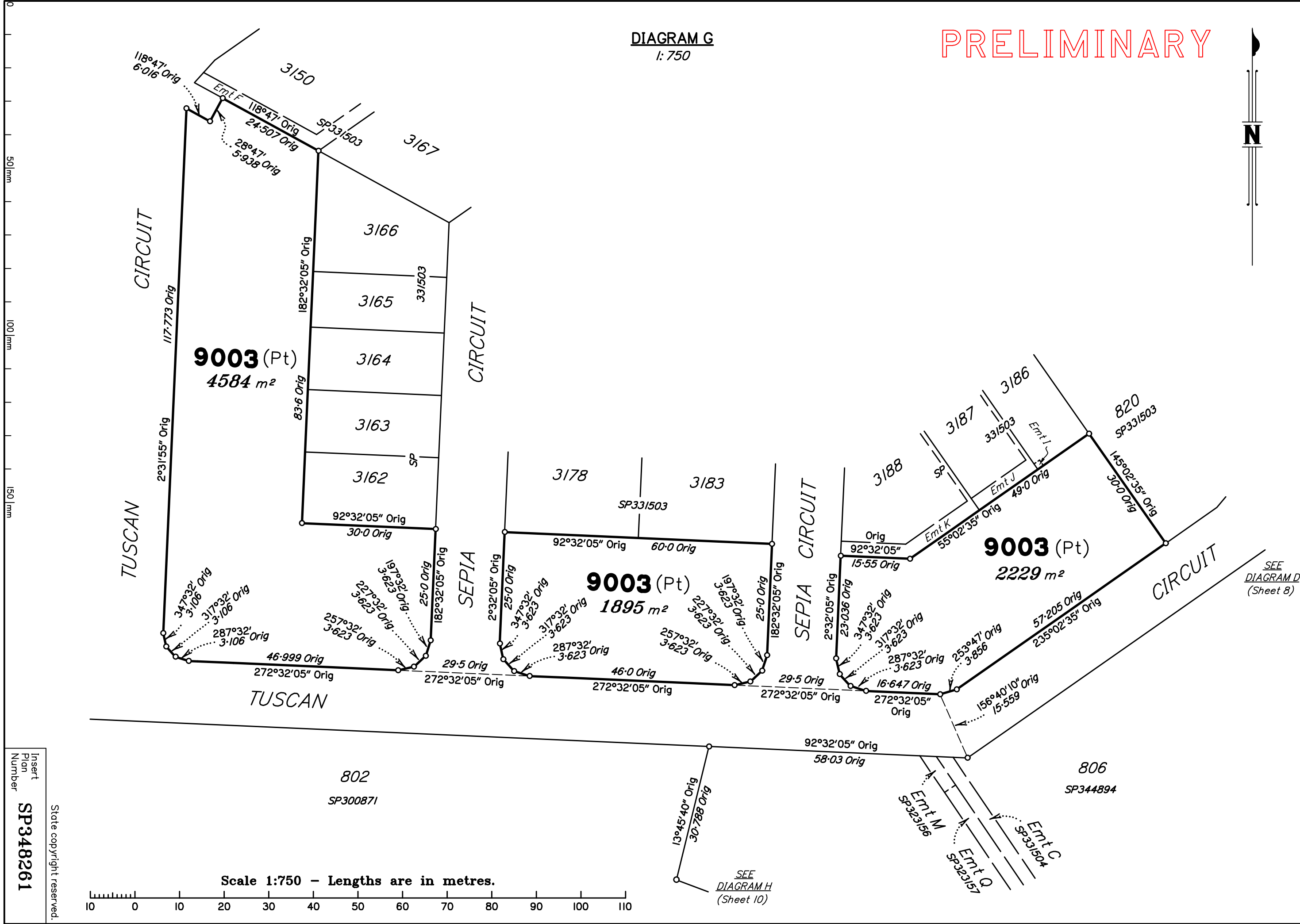


Insert Plan Number  
SP348261  
State copyright reserved.



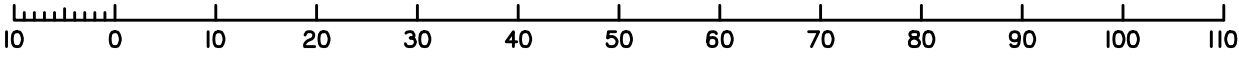
PRELIMINARY

DIAGRAM G  
1:750



Insert  
Plan  
Number  
**SP348261**  
State copyright reserved.

Scale 1:750 - Lengths are in metres.



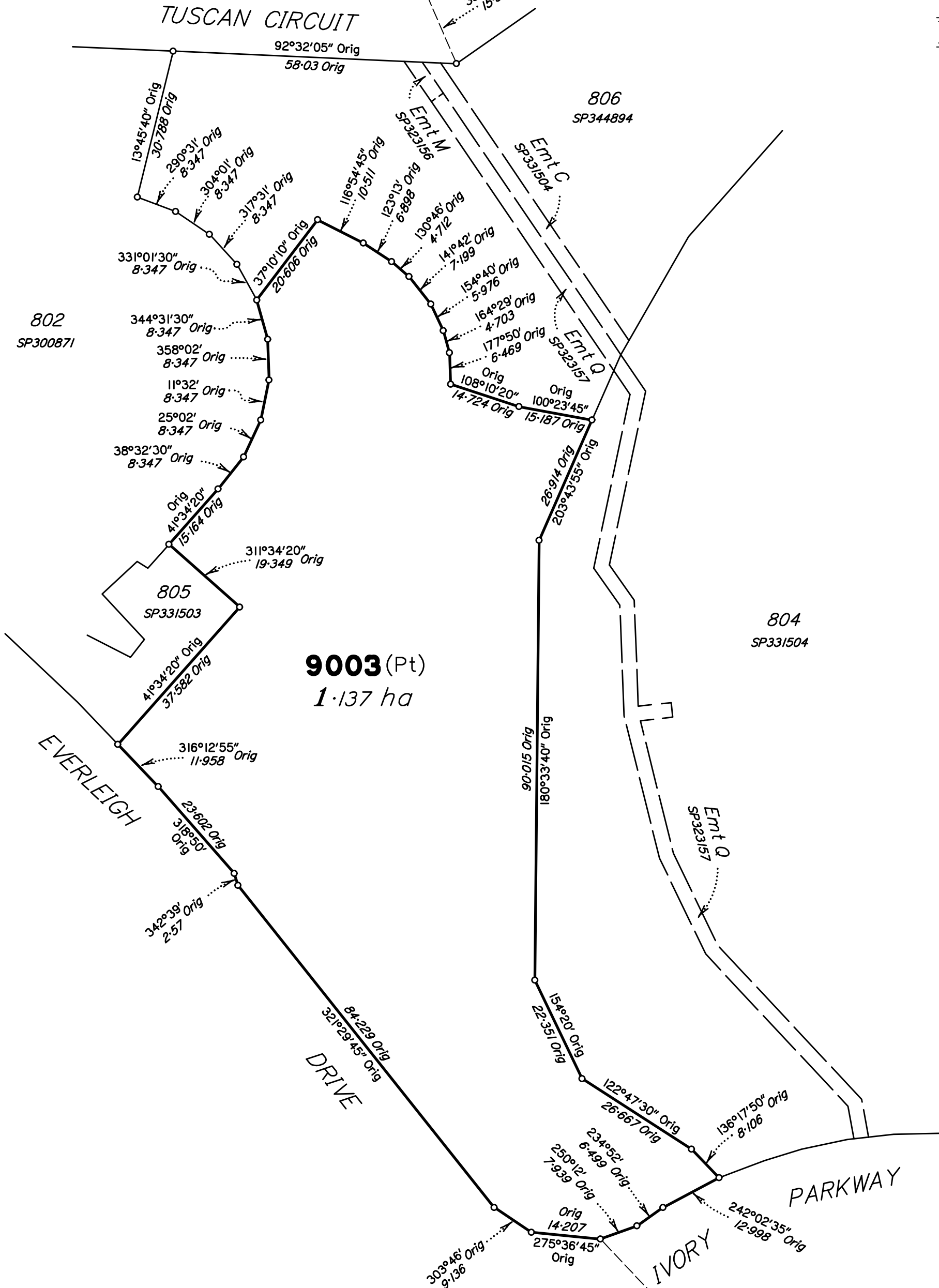
SEE  
DIAGRAM D  
(Sheet 8)

SEE  
DIAGRAM H  
(Sheet 10)

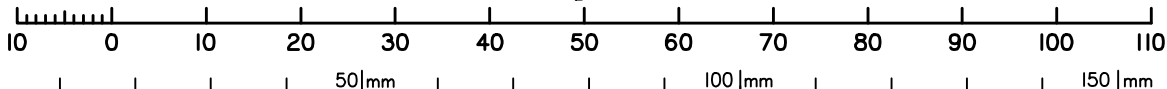
PRELIMINARY

SEE  
DIAGRAM G  
(Sheet 9)

9003 (Pt)



Scale 1:800 - Lengths are in metres.



SEE  
DIAGRAM J  
(Sheet 12)

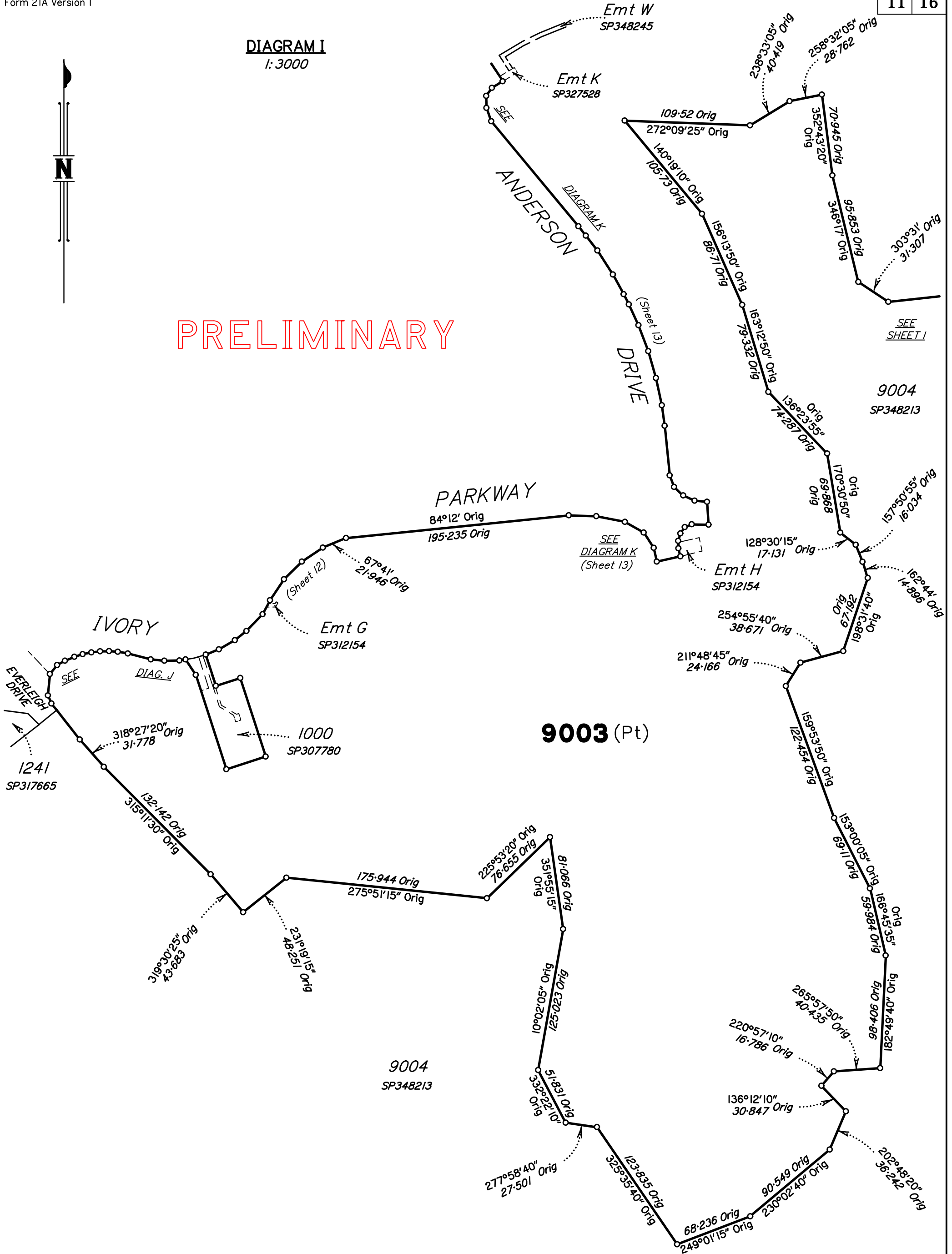
State copyright reserved.

Insert Plan Number **SP348261**

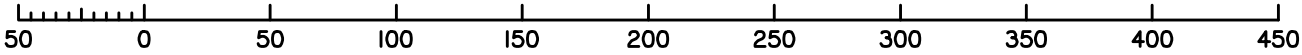
DIAGRAM I  
1:3000



PRELIMINARY



Scale 1:3000 - Lengths are in metres.

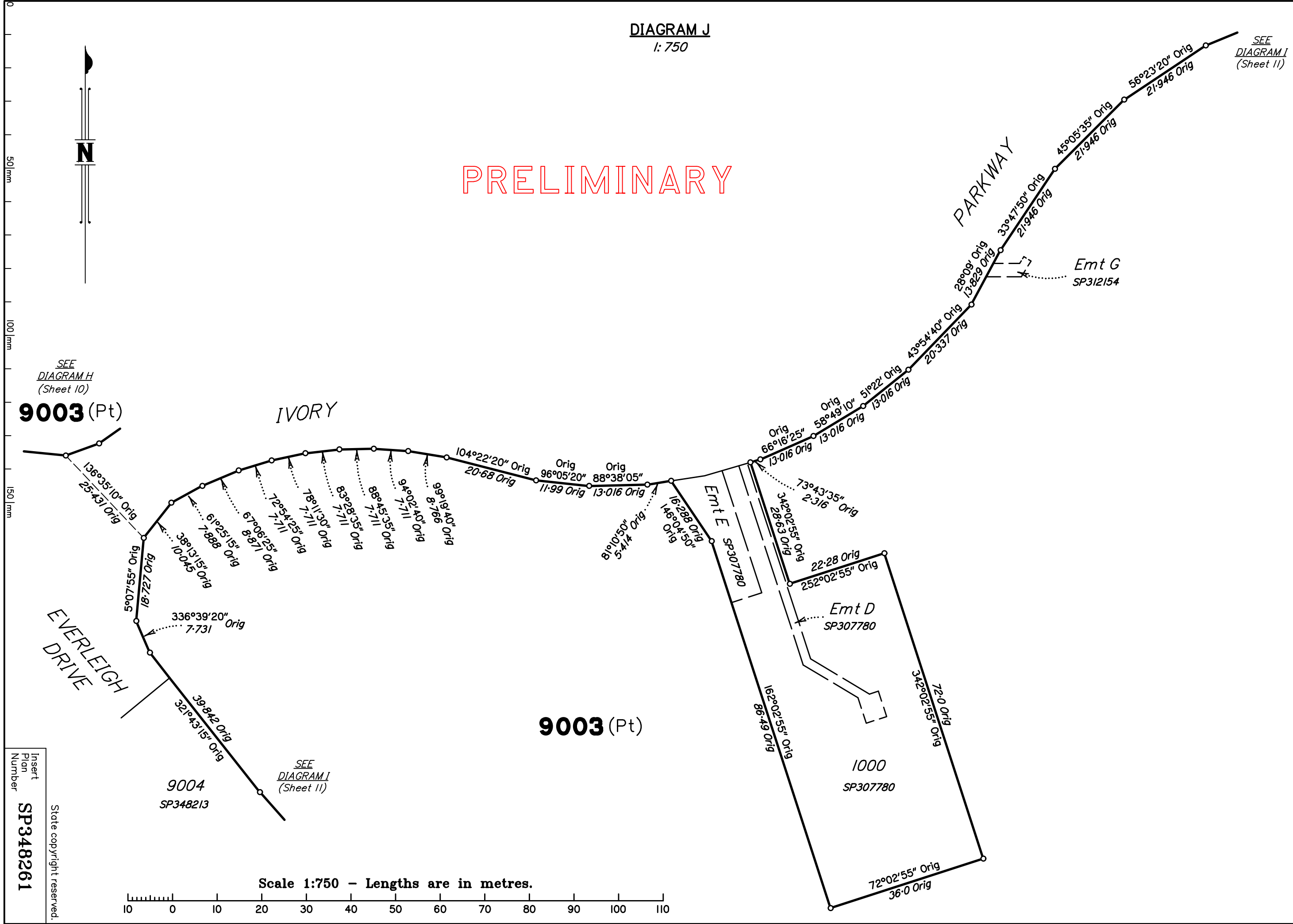


State copyright reserved.

Insert Plan Number **SP348261**

**DIAGRAM J**  
1: 750

PRELIMINARY



SEE  
DIAGRAM H  
(Sheet 10)  
**9003 (Pt)**

IVORY

**9003 (Pt)**

1000  
SP307780

Emt G  
SP312154

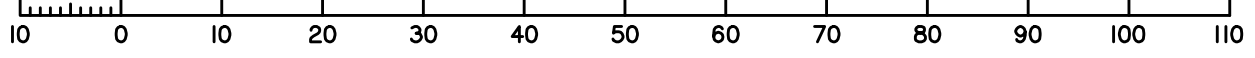
Emt E  
SP307780

Emt D  
SP307780

9004  
SP348213

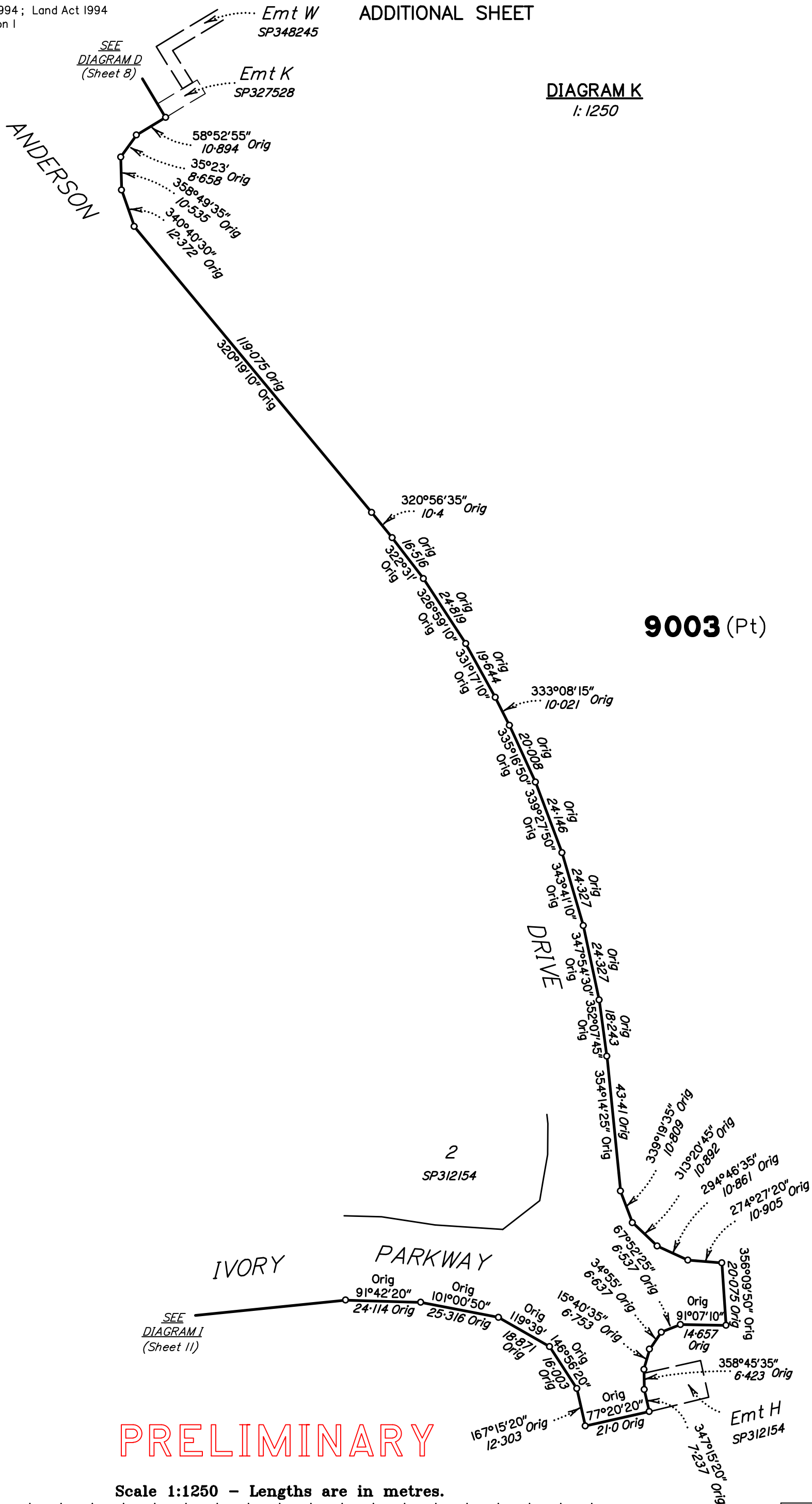
SEE  
DIAGRAM I  
(Sheet 11)

Scale 1:750 - Lengths are in metres.



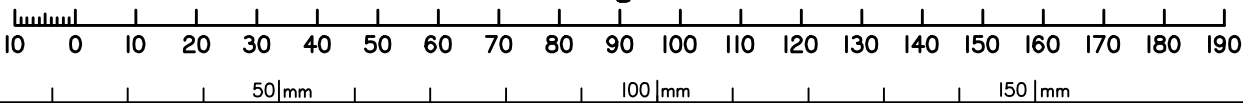
Insert  
Plan  
Number  
**SP348261**  
State copyright reserved.

SEE  
DIAGRAM I  
(Sheet 11)



PRELIMINARY

Scale 1:1250 - Lengths are in metres.

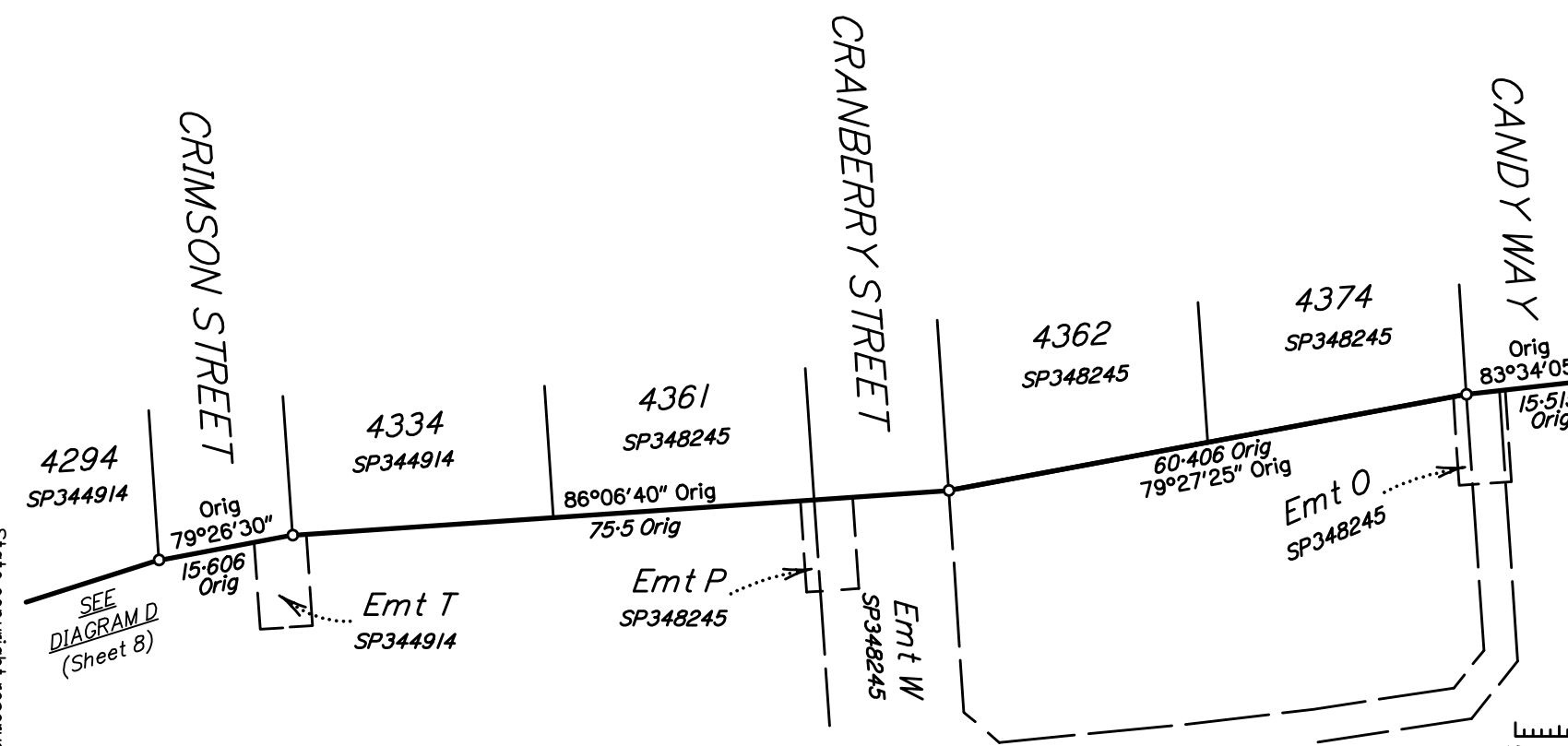
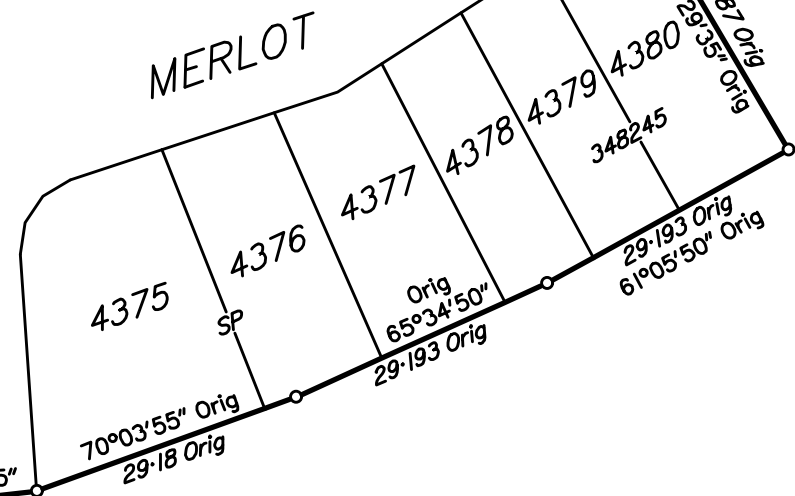
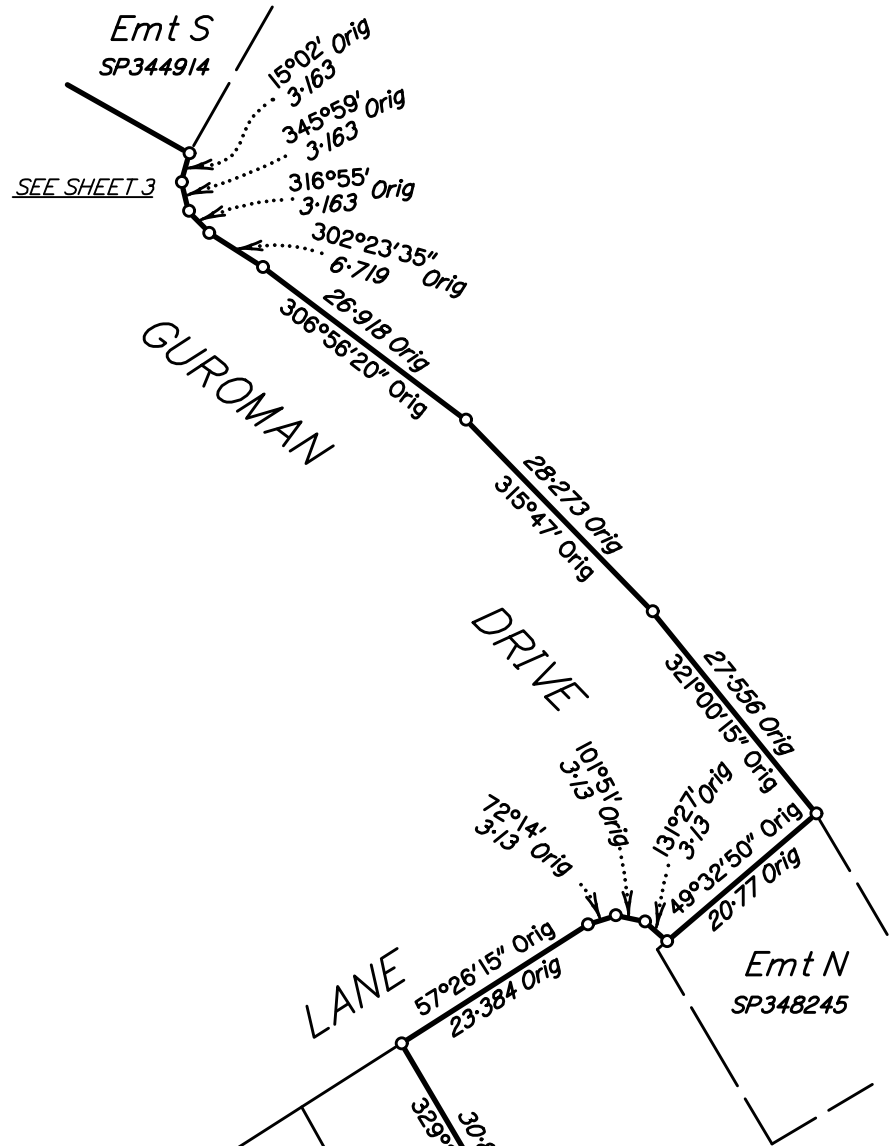


State copyright reserved.

Insert Plan Number **SP348261**

DIAGRAM L  
1:800

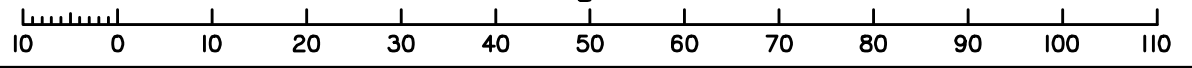
50|mm  
100|mm  
150|mm



9003 (Pt)

PRELIMINARY

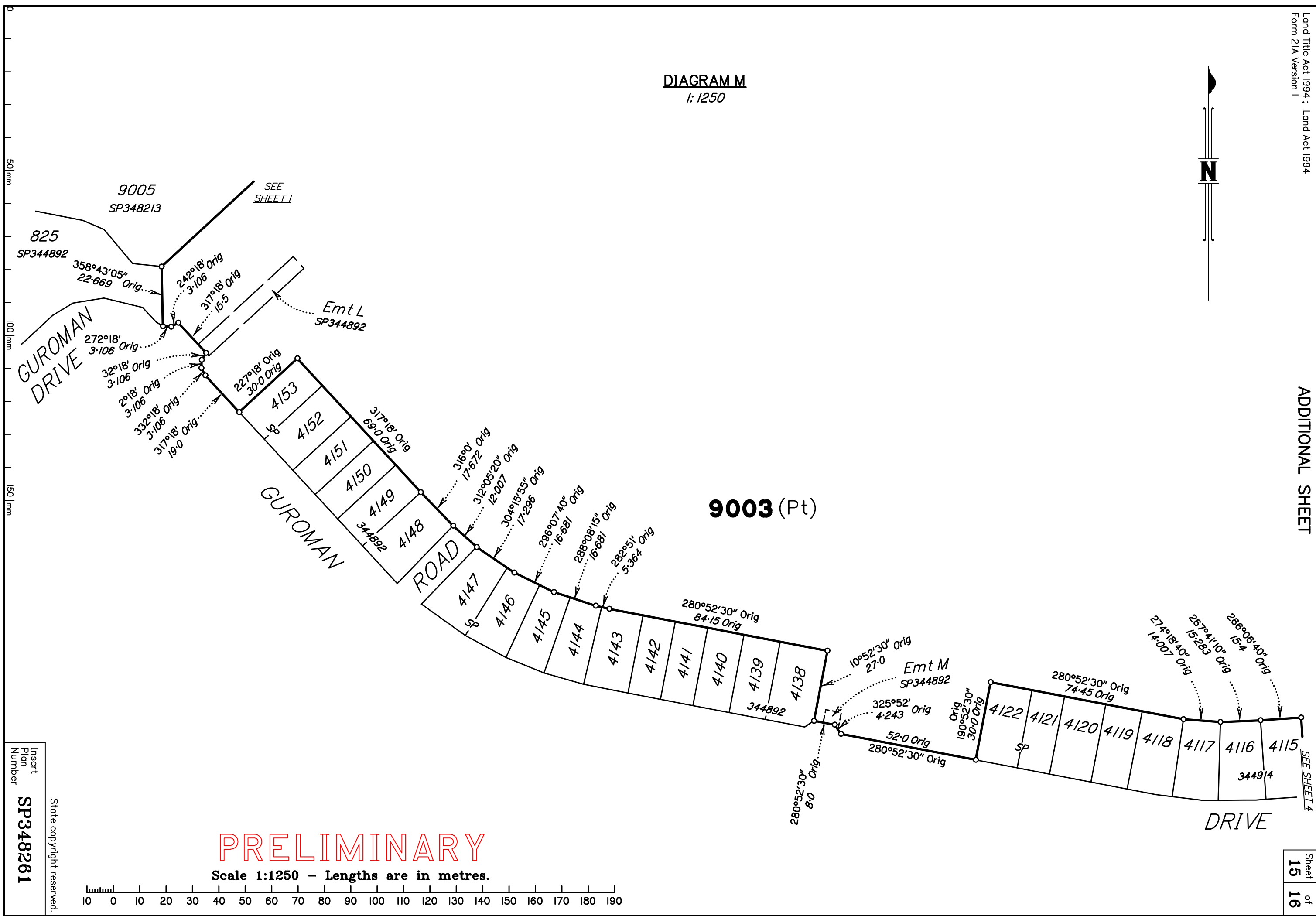
Scale 1:800 - Lengths are in metres.



Insert Plan Number  
SP348261  
State copyright reserved.

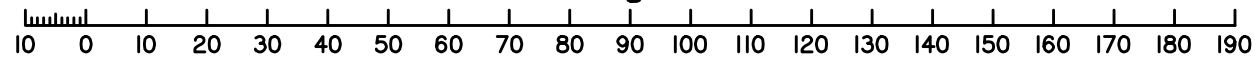


**DIAGRAM M**  
1:1250



**PRELIMINARY**

Scale 1:1250 - Lengths are in metres.



Insert  
Plan  
Number  
**SP348261**

State copyright reserved.

*M.G.A. COORDINATES (GDA-94)*

<i>STATION</i>	<i>EASTING</i>	<i>NORTHING</i>	<i>ZONE</i>	<i>P.U.</i>	<i>LINEAGE</i>	<i>METHOD</i>	<i>REMARKS</i>

*Adjustment - QLD ANJ 18.07 (16-July-2018)*

*PERMANENT MARKS*

<i>PM</i>	<i>ORIGIN</i>	<i>BEARING</i>	<i>DIST</i>	<i>NO</i>	<i>TYPE</i>

Reinstatement Report

.....  
.....  
.....

*REFERENCE MARKS*

<i>STN</i>	<i>TO</i>	<i>ORIGIN</i>	<i>BEARING</i>	<i>DIST</i>

PRELIMINARY

State copyright reserved.

Insert Plan Number **SP348261**